

PRODUCTS

TECHNICAL INFORMATION

ST30 SERIES **STACKABLE SLIDING GLASS DOORS**



PRODUCT DESCRIPTION

SYSTEM DESCRIPTION:

- › Large Missile Impact and Small Missile resistant
- › Frame depth: 8 1/8"
- › Stackable panels
- › Configurations: XX, XXX, XXXX, XXXXXX

FEATURES

- › Two or three track frames
- › Insulated/laminated (1 5/16") and laminated (9/16") glass available
- › Operate both ways
- › Attachable to adjacent window wall system
- › Two-point stainless steel locking mechanism
- › Two pairs of side adjusted tandem stainless steel rollers per operable panel

PERFORMANCE

- › Design loads:
 - + 120/-120 PSF (LMI/SMI)(See product approval charts for specific design loads capacities)
- › Water infiltration: 18 PSF

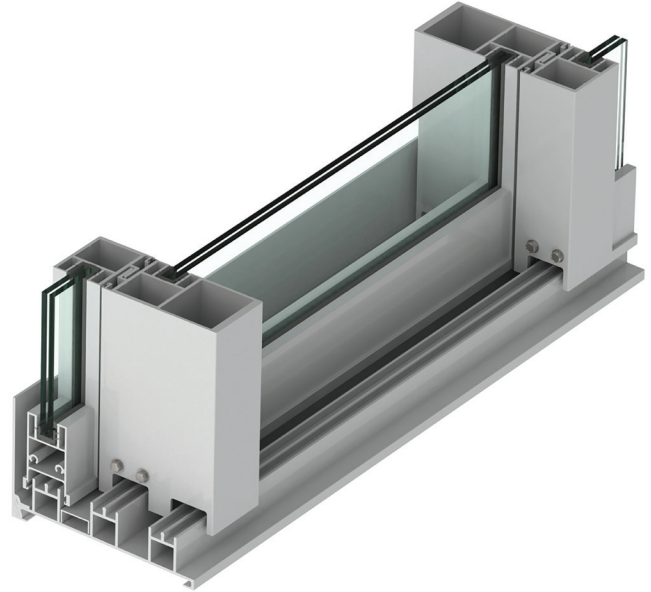

PLEASE REFER TO EPSYLON USA FLORIDA PRODUCT APPROVAL FOR CURRENT TESTED PANEL SIZE AND DESIGN PRESSURE CHARTS.

TYPICAL DETAILS

AVAILABLE CONFIGURATIONS

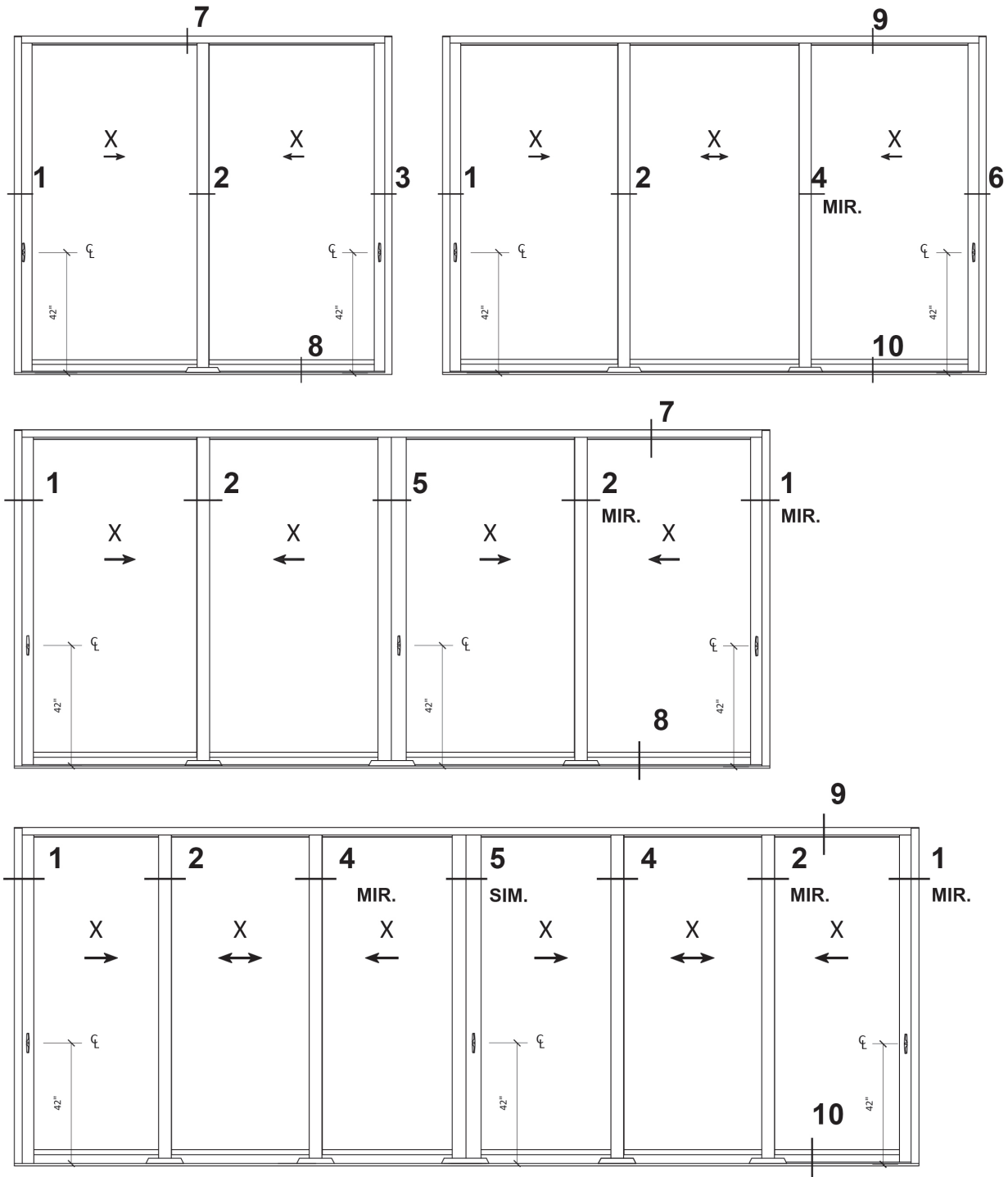

TYPICAL DETAILS

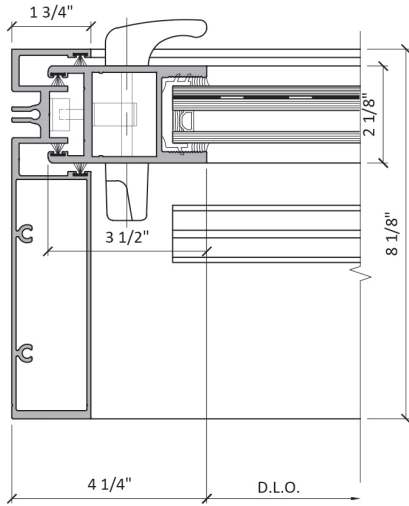

1 JAMB DETAIL

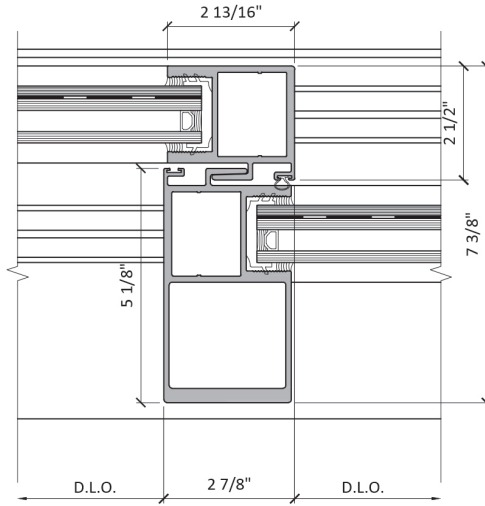

2 HEAVY DUTY MEETING STILE

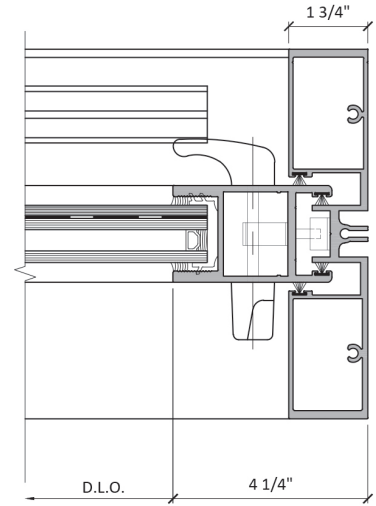

3 JAMB DETAIL

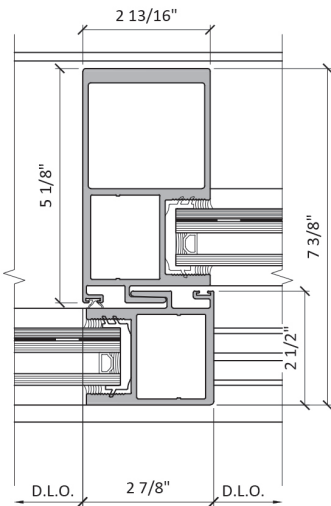

4 MEETING STILE

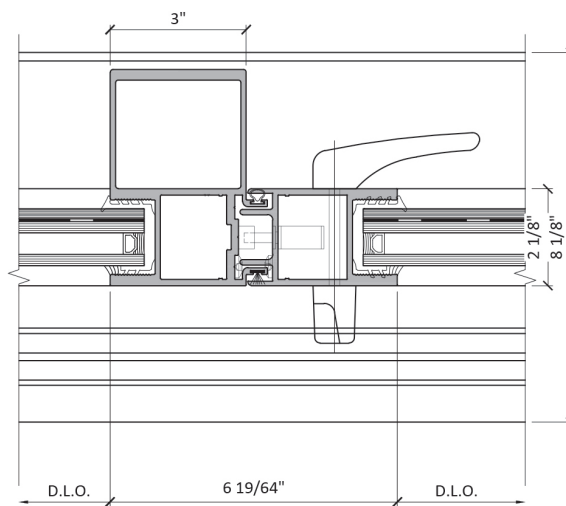

5 INTERLOCKING MEETING STILE

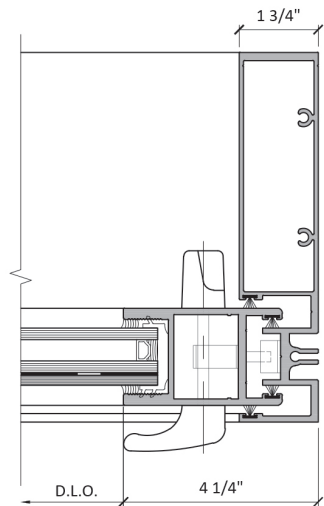

6 JAMB DETAIL

TYPICAL DETAILS

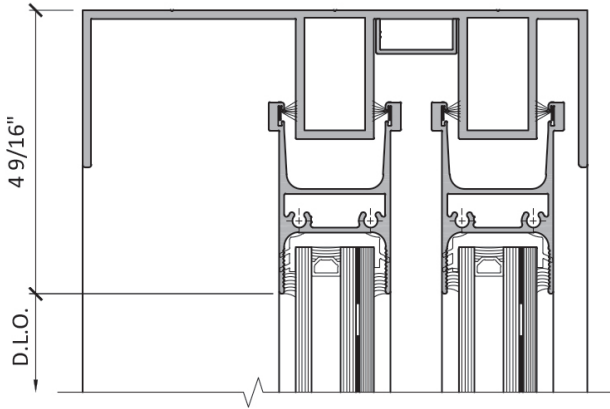

7 HEAD DETAIL

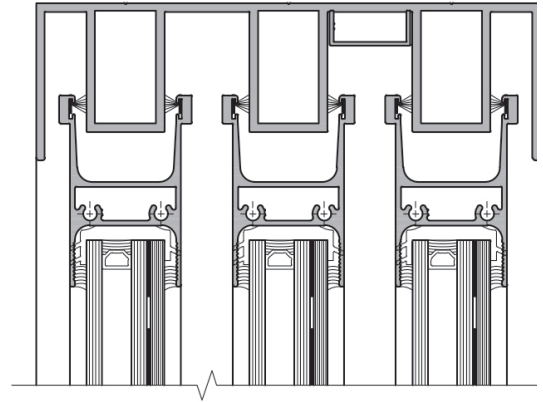

9 HEAD DETAIL

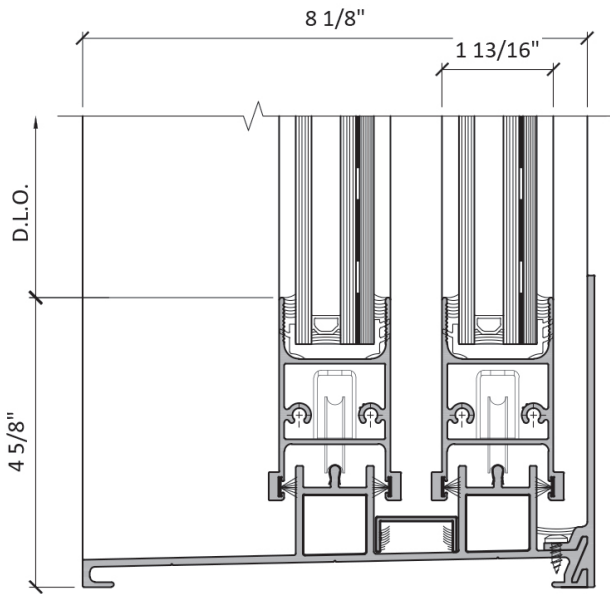

8 SILL DETAIL

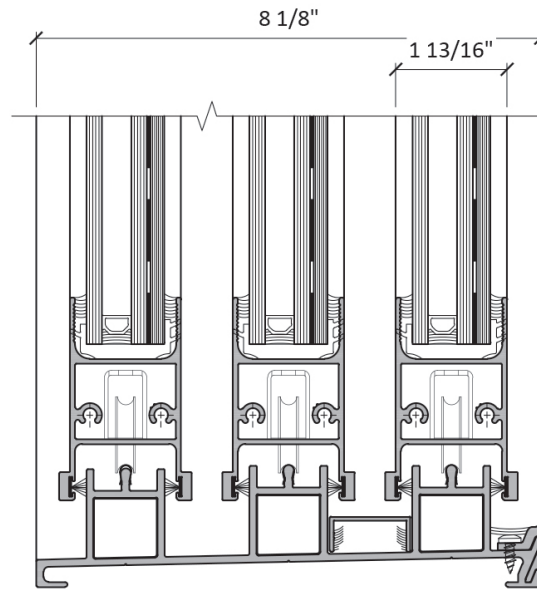

10 SILL DETAIL

Option with 1 5/16" Laminated insulated glass available



EPSYLON USA

1881 S.W. 3rd Street

Pompano Beach, FL 33069

Tel.: 954-942-3322

info@epsylon.ca
